

INCH-POUND

MIL-DTL-18375H
w/AMENDMENT 1
14 January 2010
SUPERSEDING
MIL-DTL-18375H
1 April 2005

DETAIL SPECIFICATION

WIRE ROPE, FLEXIBLE, CORROSION-RESISTING, NONMAGNETIC, FOR AIRCRAFT CONTROL

This specification is approved for use by all Departments and Agencies of the Department of Defense.

1. SCOPE

1.1 Scope. This specification covers the requirements for nonmagnetic, corrosion-resistant steel wire rope used in aircraft flight controls. The wire rope will be capable of operation within a -65 °F to +250 °F (-54 °C to +121 °C) temperature range in wind, dust, fuel and oil spills, in aircraft wash-down and other environmental stresses and aircraft experiences.

2. APPLICABLE DOCUMENTS

2.1 General. The documents listed in this section are specified in sections 3 and 4 of this specification. This section does not include documents cited in other sections of this specification or recommended for additional information or as examples. While every effort has been made to ensure the completeness of this list, document users are cautioned that they must meet all specified requirements of the documents cited in sections 3 and 4 of this specification, whether or not they are listed.

2.2 Government documents.

2.2.1 Specifications and standards. The following specification and standard form a part of this document to the extent specified herein. Unless otherwise specified, the issues of these documents are those cited in the solicitation or contract.

Comments, suggestions, or questions on this document should be addressed to Defense Supply Center Richmond, ATTN: DSCR-VEB, 8000 Jefferson Davis Highway, Richmond, VA 23297-5616 or emailed to STDZNMGT@dla.mil. Since contact information can change, you may want to verify the currency of this address information using the ASSIST database at <https://assist.daps.dla.mil/>.

MIL-DTL-18375H
w/AMENDMENT 1

DEPARTMENT OF DEFENSE SPECIFICATION

MIL-DTL-781 - Terminal, Wire Rope Swaging, General Specification
for

DEPARTMENT OF DEFENSE STANDARD

MIL-STD-129 - Military Marking for Shipment and Storage

(Copies of these documents are available online at <https://assist.daps.dla.mil/> or from the Standardization Documents Order Desk, 700 Robbins Avenue, Building 4D, Philadelphia, PA 19111-5094.)

2.3 Non-government publications. The following documents form a part of this document to the extent specified herein. Unless otherwise specified, the issues of these documents are those cited in the solicitation or contract.

ASTM INTERNATIONAL

ASTM A 342/A 342M - Standard Test Methods for Permeability of Feebly
Magnetic Materials
ASTM E 8/E 8M - Standard Test Methods for Tension Testing of Metallic
Materials

(Copies of these documents are available from <http://www.astm.org/> or from ASTM International, 100 Barr Harbor Drive, West Conshohocken, PA 19428-2959.)

SAE INTERNATIONAL

SAE HS-1086 - Metals and Alloys in the Unified Number System

(Copies of this document are available from <http://www.sae.org/> or from SAE International, 400 Commonwealth Drive, Warrendale, PA 15096-0001.)

2.4 Order of precedence. Unless otherwise noted herein or in the contract, in the event of a conflict between the text of this document and the references cited herein, the text of this document takes precedence. Nothing in this document, however, supersedes applicable laws and regulations unless a specific exemption has been obtained.

3. REQUIREMENTS

3.1 Qualification. Wire rope (see 6.4.15) furnished under this specification shall be products that are qualified for listing on the applicable qualified products list at the time of award of contract (see 4.2 and 6.3). Products must be qualified by a test facility located in the continental United States or Canada (see 4.1). The qualifying activity will be advised of any

plant relocation, changes in key personnel, or major process change(s) (e.g. changes in lubricant and/or jacketing material, changes in the lubricant application process, etc.) for requalification testing determinations.

3.2 Materials.

3.2.1 Steel. Corrosion resistant steel UNS S30500 in accordance with SAE HS-1086 shall be used.

3.2.2 Lubricant. Each wire of the wire rope shall be coated with a friction-preventive, non-corrosive lubricant. As a minimum, the lubricant shall operate at temperatures from -65 °F to +250 °F (-54 °C to +121 °C). Any change in lubricant is considered a major process change and may require requalification testing (see paragraph 3.1).

3.3 Construction.

3.3.1 Wire. The wire (see 6.4.14) used in steel wire rope shall be cylindrical, smooth and of uniformly high quality.

3.3.1.1 Wire properties. Tensile strengths of wire and wire sizes shall be such that wire rope will be capable of meeting the requirements of this specification.

3.3.1.2 Preforming (see 6.4.9) of wires and strands. The individual wires and strands composing the wire rope shall be shaped into the exact helical position they will have in the finished wire rope, so that if the wire rope is cut or severed there is no tendency for the measured diameter (see 6.4.3) of the wire rope at the unseized cut ends to increase by more than the amount specified in table I.

3.3.1.3 Splicing and joining. All splices or joints in wires less than 0.008 inch may be longitudinally twisted, but all wire sizes of 0.008 inch or more shall be brazed or welded. Any joints in individual wires in any layer of a strand (see 6.4.12) shall not be closer than 20 feet except as specified in 3.3.1.3.1.

3.3.1.3.1 Twist-off. When a twist-off (see 6.4.13) occurs during fabrication of the 7-wire layer of a 19-wire strand (see 3.3.1.3), splices and joints in individual wires may be as close as 18 inches.

3.3.2. Wire rope lengths. The wire rope shall be furnished on reels in lengths specified by the procuring activity. There will be no more than two pieces of wire rope on the reel. The shortest piece shall be a minimum of 20 percent of the reel length. The distance to the break point on the reel shall be marked on the reel and package.

3.3.3 Wire rope construction. Flexible steel wire rope shall be 7 x 7 or 7 x 19 construction and shall be regular lay (see 6.4.10) for the respective diameters, the dimensional tolerances, and the physical properties as specified in table I.

3.3.3.1 Construction 7 x 7. Wire rope of this construction shall consist of 6 outer strands of 7 wires each laid around a core strand (see 6.4.2) of 7 wires. The 6 outer strands shall each consist of a layer of 6 wires laid around a center wire (see 6.4.1) in a left-hand direction. The core strand shall consist of a layer of 6 wires laid around a center wire in a right-hand direction. The 6 outer strands shall be laid around the core strand in a right-hand direction. The length of lay (see 6.4.4 and 6.4.5) of the outside 6 wires in each of the 7 strands shall not exceed 60 percent of the lay of the finished wire rope. The length of the lay of the finished wire rope shall be not more than 8 or less than 6 times the normal rope diameter.

3.3.3.2 Construction 7 x 19. Wire rope of this construction shall consist of 6 outer strands of 19 wires each laid around a core strand of 19 wires. The 6 outer strands shall each consist of an inner layer of 6 wires laid around a center wire in a left-hand direction and an outer layer of 12 wires laid over the inner layer of 6-wire layer in a left-hand direction. The core strand shall consist of an inner layer of 6 wires laid around a center wire in a right-hand direction and an outer layer of 12 wires laid over the inner 6-wire layer in the right-hand direction. The 6 outer strands shall be laid around the core strand in a right-hand direction. The length of lay of the inner 6-wire layer in each of the 7 strands shall not exceed 60 percent of the lay of the outer 12-wire layer. The length of lay of the outer 12-wire layer in each of the 7 strands shall not exceed 50 percent of the lay of the finished wire rope. The length of lay of the finished wire rope shall be not more than 8 times or less than 6 times the nominal wire rope diameter.

3.4 Performance.

3.4.1 Breaking strength. The wire rope shall have the minimum breaking strength (MBS) (see 6.4.7) shown in table I.

3.4.2. Endurance. The wire rope shall be capable of withstanding the respective tension load and number of reversals shown in table II without failure. The breaking strength of the wire rope after the endurance test shall be not less than specified in table II.

3.4.3 Stretch limits. The wire rope shall not stretch more than 1.5 percent under a load equal to 60 percent of the applicable MBS shown in table I.

3.4.4 Ductility of steel. Wire shall not fracture when wrapped in accordance with 4.5.5 prior to wire rope fabrication.

3.4.5 Test load. The wire rope shall be capable of carrying 80 percent of its respective MBS load shown in table I without any failures of the individual wires in the rope.

3.4.6 Magnetic permeability. The magnetic permeability of the wire rope shall not exceed 1.5 in a magnetic field of 200 oersteds.

3.4.7 Operating range. The wire rope shall be capable of operation in wind, dust, fuel, and oil spills, wash-down and other aircraft environmental stresses and experiences within a -65 °F to +250 °F (-54 °C to +121 °C) temperature range.

3.5 Identification of product. The wire rope shall be identified in accordance with the following:

3.5.1 Identification by number. Each manufacturer shall assign a significant identification number on each manufacturing reel of wire rope. When the wire rope on the manufacturing reel is cut to specified lengths for transfer to the shipping reel (see 6.4.11), each shipping reel shall be marked with the identification number of the manufacturing reel.

3.5.2 Identification by color tracer filament. Each manufacturer shall identify every wire rope by the use of color filaments manufactured into the rope. The specification preparing activity will assign a combination of colors to each manufacturer desiring qualification. The inclusion of color tracing filaments alone does not designate that the wire rope is in full conformance with this specification or has met qualification requirements, but only serves to identify the manufacturer.

3.5.3 Identification of reels and shipping containers. Each shipping reel and shipping container shall be marked in accordance with the requirements of MIL-STD-129. The following information shall be included:

- a. Stock No. or identification as specified in the contract. 1/
- b. Size (include diameter of wire rope and construction).
- c. Name of wire rope manufacturer.
- d. Name of contractor.
- e. Contractor order number.
- f. Type of wire rope construction and specification number (MIL-DTL-18375).
- g. Date of manufacture (month/year).
- h. For reels with 2 lengths of wire rope, record distance from outside end to separation point and total length of wire rope on the reel.
- i. Manufacturing reel/lot number.

1/ The contractor shall enter the National Stock Number (NSN) specified in the contract or as furnished by the procuring activity. Space shall be left for the NSN when not available.

3.6 Workmanship and finish. All details of workmanship and finish shall be in accordance with the best practice for high quality aircraft wire rope consistent with the requirements of this specification. The finished wire rope shall be uniform in construction and securely laid, free from kinks, loose wires, loose strands, non-uniform gaps between strands that coincide with the length of lay of the outer strands, or other defects (4.5.1.1).

4. VERIFICATION

4.1 Classification of inspection. The inspection and testing of the wire rope shall be classified as follows:

- a. Qualification inspection (see 4.2).
- b. Conformance inspection (see 4.3).

4.2 Qualification inspection.

4.2.1 Qualification inspection samples. When conducting qualification tests specified herein, one sample lot for each size and construction of wire rope listed in table I, for which qualification is desired, shall be taken after any discard has been removed from the head or starting end of the first manufacturing reel for each lot of wire rope.

4.2.1.1 Lot. A qualification inspection lot shall consist of 50 feet of wire rope of the same construction and diameter produced continuously by one machine or by one series of progressive processing machines.

4.2.2 Qualification testing. Qualification tests shall be performed for each size and construction of wire rope for which qualification is desired as specified in table III.

4.2.3 Maintenance of qualification. To maintain qualification, the manufacturer must be able to demonstrate that the company still has the capabilities and facilities necessary to produce the items. The qualifying activity will request appropriate documentation demonstrating this capability at the time qualification retention is required (at least 2-year intervals).

4.3 Conformance inspection. Conformance inspection shall consist of individual tests and sampling tests.

4.3.1 Individual tests. Wire rope of each size and construction furnished under each contract or order shall be subject to the following test for determining conformance to the applicable requirements shown in table III.

- a. Examination of product (4.5.1.1).
- b. Conformance test to preforming of wire rope (4.5.1.2).
- c. Identification of product (4.5.1.3).
- d. Ductility of steel (4.5.5).

4.3.2 Sampling plan.

4.3.2.1 Sampling. When conducting the sampling tests specified herein, one continuous sample of sufficient length shall be taken after any discard has been removed from the head or starting end of the first manufacturing reel for each lot of wire rope.

4.3.2.2 Lot. A lot shall consist of not more than 20,000 feet of wire rope of the same construction and diameter produced continuously by one machine or by one series of progressive processing machines.

4.3.2.3 Specimen. A specimen is a piece of wire rope cut from a sample for the performance of a specific conformance test.

4.3.3 Sampling tests. The following conformance sampling tests shall be performed on each lot of wire rope in accordance with the applicable paragraphs shown in table III. One

specimen shall be tested per test. All the specimens shall be from the respective wire rope sample taken in accordance with 4.3.2.1.

- a. Breaking strength (4.5.2).
- b. Endurance test (4.5.3).
- c. Stretch test (4.5.4).
- d. Test load (4.5.6).
- e. Magnetic permeability (4.5.7).

4.4 Certification. For each contract or order, the wire rope manufacturer shall certify that the product satisfactorily passed the conformance inspections (see 4.3.1 and 4.3.3) of this specification. The certification shall include, as a minimum, actual results of the tests specified herein and shall be retained on file at the manufacturer's facility for a minimum of 7 years.

4.5 Test methods.

4.5.1 Examination of product.

4.5.1.1 Examination of product. Each sample of wire rope shall be visually examined for workmanship and finish to determine compliance with 3.6.

4.5.1.2 Conformance test to preforming of wire rope. To test wire rope for conformity to values shown in table I for increase in diameter, the wire rope shall be mechanically cut with a cutter having constricting jaws. A plain shear with straight blades distorts the product and may void the test. After cutting, the wire rope shall be measured by passing the wire rope through a hole drilled to a diameter increased as shown in table I under "Allowable increase in diameter at cut end" or by using a shadowgraph with suitable magnification. The allowable increase in diameter shall be applied to the actual diameter of the wire rope being tested.

4.5.1.3 Identification of product. Each wire rope and shipping reel shall be inspected for proper identification as specified in 3.5.1, 3.5.2, and 3.5.3.

4.5.2 Breaking strength. A specimen for each size and construction of wire rope shall be selected from the sample from each lot. The specimen shall be no less than 24 inches in length, and where necessary, swaged terminals conforming to MIL-DTL-781 (do not use ball end fittings) and accompanying hardware may be used to facilitate installation of the specimen in the jaws of the testing machine. The length of wire rope sample under load shall be no less than 10 inches. The breaking strength shall be determined by use of a tensile testing machine in accordance with applicable requirements of ASTM E 8/E 8M. The breaking strength shall conform to the requirement of table I. In case of failure due to an unsatisfactory end termination, the test will be disregarded and a new test conducted.

4.5.3 Endurance test. The wire rope specimen and test machinery shall conform to figure 1. The number of reversals and tension loads shall be as specified in table II for the respective wire rope sizes. The total travel of the wire rope per reversal shall be 13 1/2 inches. The test sheaves shall be made of steel and shall conform to the dimensions of figure 2 and

table IV. The application of lubricant to the endurance test sample, in addition to the lubricant applied during the manufacture of wire rope, shall not be permitted either before or during the endurance test. The breaking strength of the wire rope specimen after the endurance test shall be determined by the method specified. The test specimen shall be that portion of the wire rope that passes over one of the test sheaves during the endurance test. The breaking strength shall be equal to or greater than the corresponding MBS specified in table II.

4.5.4 Stretch test. The total length of the wire rope specimen to be tested shall not be less than 24 inches. When necessary, swaged terminals and accompanying hardware may be used to facilitate installation of the specimen in the jaws of the test machine. The amount of stretch shall be determined on a tension testing machine in accordance with ASTM E 8/E 8M. The specimen shall be loaded to 1 percent of applicable MBS shown in table I to straighten the wire rope. While the specimen is under the 1 percent preload, a gauge length of not less than 10 inches shall be marked on the wire rope between the end fittings of the test specimen. The specimen shall then be loaded to 60 percent of the wire rope's MBS and measured for elongation under this load. The percent stretch shall be calculated using the formula below.

$$\text{Percent stretch} = \frac{\text{Elongation of gauge length under load}}{\text{Original gauge length}} \times 100 \leq 1.5\%$$

4.5.5 Ductility of steel. The wire shall be wrapped in a way that does not cause indenting. The wire shall be wrapped around a cylindrical mandrel for 2 complete turns in a close helix at a rate not exceeding 15 turns per minute. The cylindrical mandrel diameter shall be equal to the nominal wire diameter being tested.

4.5.6 Test load. The following test shall be made using the same wire rope specimen used in the stretch test, or similarly prepared specimen. Load the specimen to one percent of breaking strength and then increase the loading to 80 percent of the minimum required breaking strength of the wire rope specified in table I. The load shall be applied for 5 seconds. At the end of the test, the entire rope shall be completely unwound and every wire inspected. A suitable electronic device capable of detecting the breaking of individual wires during testing may be used instead of unwinding the wire rope. The failure of any wire shall be cause for rejection (see 4.5.6.1).

4.5.6.1 Use of acoustic, electronic device for wire break test. The load shall be increased to 80 percent on the test specimen. If no ping (see 6.4.8) is heard, the specimen has passed the test. If one or more pings are heard, the wire rope specimens shall be unraveled and the broken wires shall confirm failure of the specimen. If no broken wires are found, the specimen has passed the test.

4.5.7 Magnetic permeability. Each sample selected shall be inspected with the permeability indicator specified in ASTM A 342/A 342M. All indications shall establish that the permeability of the material does not exceed 1.5.

4.6 Preparation for delivery. The preservation, packaging, packing, and marking shall be examined for conformance to section 5.

5. PACKAGING

5.1 Packaging. For acquisition purposes, the packaging requirements shall be as specified in the contract or order (see 6.2). When packaging of material is to be performed by DoD or in-house contractor personnel, these personnel need to contact the responsible packaging activity to ascertain packaging requirements. Packaging requirements are maintained by the Inventory Control Point's packaging activities within the Military Service or Defense Agency, or within the military service's system commands. Packaging data retrieval is available from the managing Military Department's or Defense Agency's automated packaging files, CD-ROM products, or by contacting the responsible packaging activity.

6. NOTES

(This section contains information of a general or explanatory nature that may be helpful, but is not mandatory.)

6.1 Intended use. The wire rope covered by this specification is intended for use in aircraft control systems applications where low magnetic permeability is needed. Wire rope conforming to composition B of MIL-DTL-83420 has higher strength and magnetic permeability than wire rope conforming to this specification.

6.1.1 Application limitations. Leak-out evaporation of the lubricant applied to the wire rope during fabrication and preparation for shipment can be expected. Therefore, upon installation and periodically throughout the service life, the wire rope should be lubricated. The method of lubrication, frequency, and identity of the approval military standard lubricant should be included in the appropriate aircraft maintenance manuals.

6.2 Acquisition requirements. Acquisition documents should specify the following:

- a. Title, number, and date of this specification.
- b. Size, construction, and length of wire rope per reel to be furnished.
- c. Packaging requirements (see 5.1).

6.3 Qualification. With respect to products requiring qualification, awards will be made only for products that are, at the time of award of contract, qualified for inclusion in QPL-18375 whether or not such products have actually been so listed by that date. The attention of contractors is called to these requirements, and manufacturers are urged to arrange to have the products that they propose to offer to the Federal Government tested for qualification in order that they may be eligible to be awarded contracts or orders for the products covered by this specification. Information pertaining to qualification of products may be obtained from Defense Supply Center Richmond, ATTN: DSCR-VEB, 8000 Jefferson Davis Highway, Richmond, VA 23297-5616 or STDZNMGT@dla.mil.

6.4 Definitions.

6.4.1 Center wire. The center of all strands is an individual wire and is designated as a center wire.

6.4.2 Core strand. A strand core consists of a single straight strand made of wires similar to the other strands comprising the wire rope in arrangement and number of wires.

6.4.3 Diameter. The diameter of wire rope is the diameter of the circumscribing circle, or the distance across the opposite strands.

6.4.4 Lay (twist). The helical form taken by the wires in the strand and by the strand in the wire rope is characterized as the lay (twist) of the strands or wire rope, respectively. In a right-hand lay, the wires of strands are the same direction as the thread on a right-hand screw, and for a left-hand lay, the strands or wires lay in an opposite direction.

6.4.5 Length of lay (pitch). The distance parallel to the axis of the strand or cable, in which a wire or strand makes one complete turn about the axis, is designated as the length of lay (pitch) of the strand or wire rope.

6.4.6 Master reel. The master reel is the large manufacturing reel that is used to hold the wire rope as it is continuously manufactured.

6.4.7 Minimum breaking strength. The minimum tension load that a wire rope must support.

6.4.8 Ping. Ping is an audible sound given off as a result of an individual wire breaking in the wire rope. The sound is amplified and fed into a speaker system to a level distinctly detectable by the human ear.

6.4.9 Preforming. Wire and strand shaped, during fabrication of the wire rope, to conform to the form or curvature that they take in the finished wire rope.

6.4.10 Regular lay. Wire rope in which the direction of the lay of the wires in the strand is in an opposite direction to the lay of the strand in the wire rope.

6.4.11 Shipping reel. The shipping reels are cut from the master reel (see 6.4.6) as needed.

6.4.12 Strand. Each group of wires helically twisted is designated as a strand.

6.4.13 Twist-off. Twist-off is a twisting severance of the strand or wire due to a malfunctioning of the stranding equipment.

6.4.14 Wire. Each individual cylindrical element is designated as a wire.

6.4.15 Wire rope. A group of 3 or more strands helically twisted is designated as a wire rope.

6.5 Subject term (key word) listing.

Aircraft
Guide
Magnetic
Pliable
Steel wire rope

6.6 Amendment notations. The margins of this specification are marked with vertical lines to indicate where modifications from this amendment were made. This was done as a convenience only and the Government assumes no liability whatsoever for any inaccuracies in these notations. Bidders and contractors are cautioned to evaluate the requirements of this document based on the entire content irrespective of the marginal notations.

MIL-DTL-18375H
w/AMENDMENT 1

TABLE I. Wire rope construction and physical properties.

Diameter of wire rope		Tolerance on diameter (plus only)	Allowable increase of diameter at cut end <u>1/</u>	Construction	MBS before endurance testing	Approximate weight per 100 ft.
Nominal (reference)	Minimum					
in.	in.	in.	in.		lbs.	lbs.
1/16	0.062	0.010	0.009	7 x 7	360	0.75
3/32	0.093	0.012	0.010	7 x 7	700	1.60
1/8	0.125	0.014	0.011	7 x 19	1,300	2.90
5/32	0.156	0.016	0.017	7 x 19	2,000	4.50
3/16	0.187	0.018	0.019	7 x 19	2,900	6.50
7/32	0.218	0.018	0.020	7 x 19	3,800	8.60
1/4	0.250	0.018	0.021	7 x 19	4,900	11.00
9/32	0.281	0.020	0.023	7 x 19	6,100	13.90
5/16	0.312	0.022	0.024	7 x 19	7,600	17.30
3/8	0.375	0.026	0.027	7 x 19	11,000	24.30

1/ The allowable increase in diameter shall be applied to the actual diameter of the wire rope being tested.

TABLE II. Wire rope endurance test parameters and breaking strength after endurance testing.

Nominal diameter of wire rope	Construction	Endurance test parameters <u>1/</u>		MBS after endurance testing <u>4/</u>
		Minimum tension load (-0, +10%) <u>2/</u>	Number of reversals <u>3/</u>	
in.		lbs.		lbs.
1/16	7 x 7	5.0	70,000	216
3/32	7 x 7	9.0	70,000	420
1/8	7 x 19	18.0	70,000	780
5/32	7 x 19	24.0	130,000	1,200
3/16	7 x 19	37.0	130,000	1,740
7/32	7 x 19	50.0	130,000	2,280
1/4	7 x 19	64.0	130,000	2,940
9/32	7 x 19	78.0	130,000	3,660
5/16	7 x 19	90.0	130,000	4,560
3/8	7 x 19	120.0	130,000	6,600

1/ The tension loads and number of reversals are test parameters only and are by no means intended as design criteria.

2/ Tension load is equal to one-half the weight (w) as shown in figure 1.

3/ 2 reversals = 1 cycle. 13 1/2 inches of travel in one direction and return.

4/ Each value is equal to 60 percent of the original MBS of the wire rope as shown in table I.

MIL-DTL-18375H
w/AMENDMENT 1

TABLE III. Qualification and conformance tests and inspections.

Tests	Requirement paragraph	Qualification paragraph	Conformance paragraph
Workmanship and finish	3.6	4.5.1.1	4.5.1.1
Preforming of wires and strands	3.3.1.2	4.5.1.2	4.5.1.2
Identification of product	3.5.1 - 3.5.3	4.5.1.3	4.5.1.3
Breaking strength	3.4.1	4.5.2	4.5.2
Endurance test	3.4.2	4.5.3	4.5.3
Stretch test	3.4.3	4.5.4	4.5.4
Ductility of steel	3.4.4	4.5.5	4.5.5
Test load	3.4.5	4.5.6 - 4.5.6.1	4.5.6 - 4.5.6.1
Magnetic permeability	3.4.6	4.5.7	4.5.7

TABLE IV. Dimensions of test sheaves used in endurance test. 1/

		Sheaves ratio	C <u>2/</u> <u>3/</u>	G <u>2/</u>	D	Er
Nominal diameter of wire rope (d)	Construction	(D/d)	$\pm .015$	+1/64 -1/64	+ .005 - .000	+ .002 - .000
in.			in.	in.	in.	in.
1/16	7 x 7	16.0	1.188	3/8	1.000	0.036
3/32	7 x 7	13.5	1.531	3/8	1.250	0.052
1/8	7 x 19	7.0	1.250	3/8	0.875	0.069
5/32	7 x 19	9.5	1.953	3/8	1.484	0.086
3/16	7 x 19	9.5	2.343	1/2	1.781	0.102
7/32	7 x 19	9.5	2.734	1/2	2.078	0.118
1/4	7 x 19	9.5	3.125	1/2	2.375	0.134
9/32	7 x 19	9.5	3.515	1/2	2.671	0.150
5/16	7 x 19	9.5	3.907	9/16	2.969	0.167
3/8	7 x 19	9.5	4.687	9/16	3.562	0.200

1/ The dimensions of the test sheaves are test parameters only and are by no means intended as design criteria.

2/ Reference dimension may be varied at manufacturer's direction.

3/ $C=D+3d$

MIL-DTL-18375H
w/AMENDMENT 1

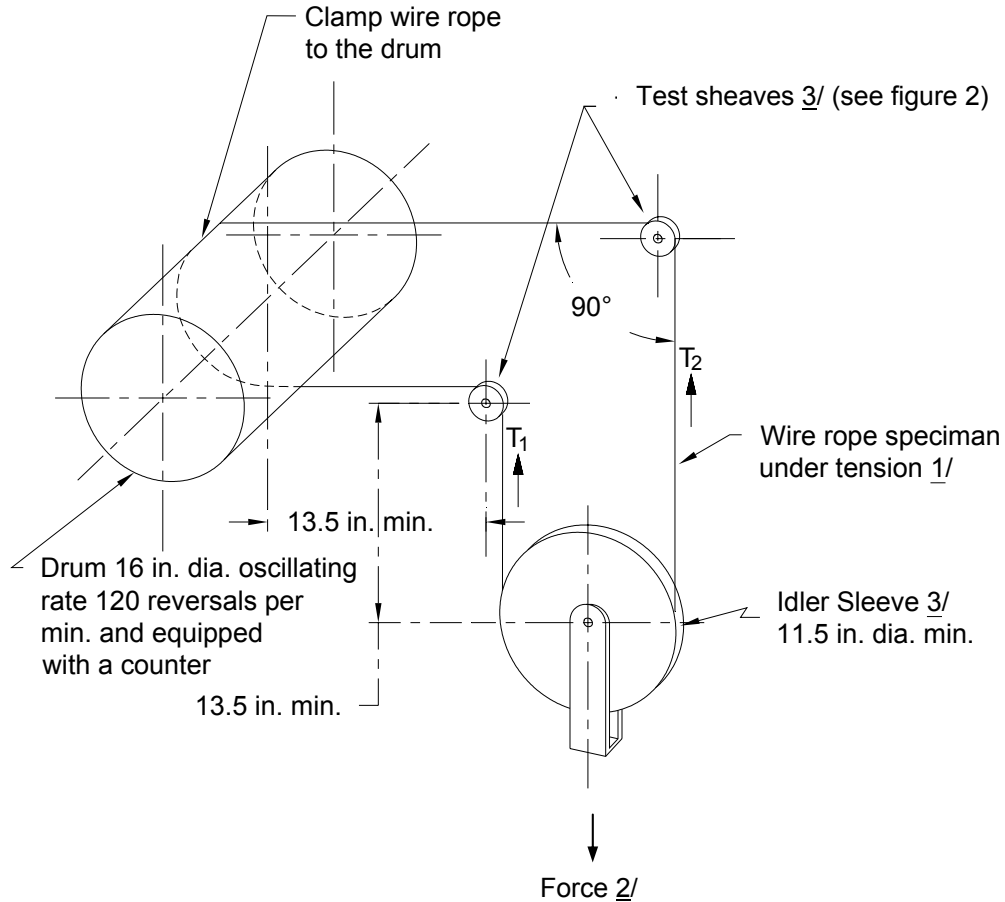

NOTES:

1/ Tension load per table II $T_1 = T_2 = w/2$

2/ Force necessary to develop the applicable tension load = $w = w_1 + w_2 + w_3$, where

w_1 = weight of idler sheaves

w_2 = weight of hanger

w_3 = weight added to hanger to make the total weight "w" equal to twice the applicable tension load

3/ All sheaves shall be supported on suitable ball or roller bearing, or on shaft extensions supported on suitable ball or roller bearings.

4/ The dimensions of the test sheaves are test parameters only and are by no means intended as design criteria.

FIGURE 1. Diagram of endurance testing machine and conditions of the test.

MIL-DTL-18375H
w/AMENDMENT 1

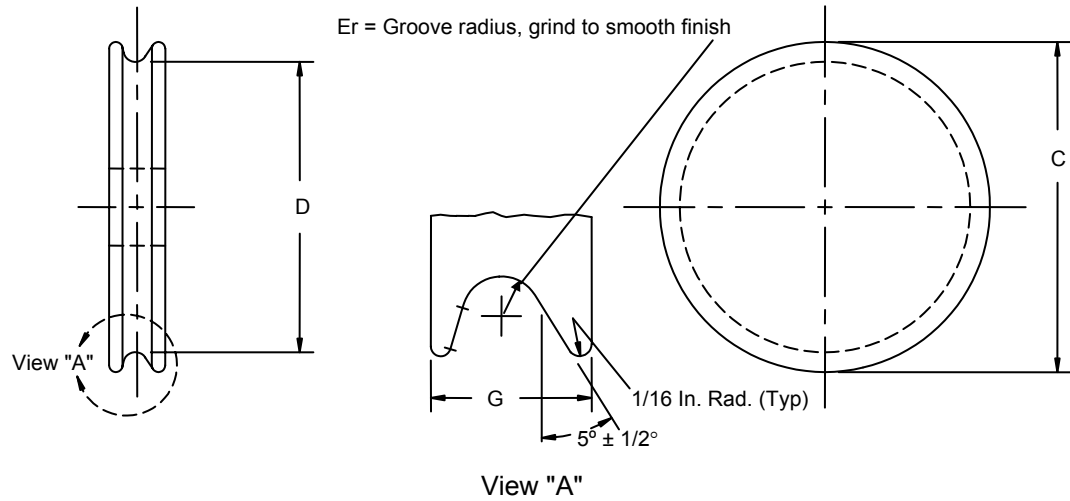

Material: Tool steel.

Heat Treat: Harden to Rockwell C60 minimum.

NOTE:

1. Sheave dimensions per table IV.

FIGURE 2. Test sheaves used in standard endurance test.

MIL-DTL-18375H
w/AMENDMENT 1

Custodians:

Army - MI
Navy - AS
Air Force - 99
DLA - GS

Preparing Activity:

DLA - GS5

(Project 1640-2009-011)

Review Activities:

Army - CR4
Air Force - 11, 71

NOTE: The activities listed above were interested in this document as of the date of this document. Since organizations and responsibilities can change, you should verify the currency of the information above using the ASSIST database at <https://assist.daps.dla.mil/>.