

DETAIL SPECIFICATION SHEET

TERMINAL, WIRE ROPE, SWAGING, FORK END

This specification is approved for use by all Departments and Agencies of the Department of Defense.

The requirements for acquiring the product described herein shall consist of this specification sheet, MIL-DTL-781, and QPL-781.

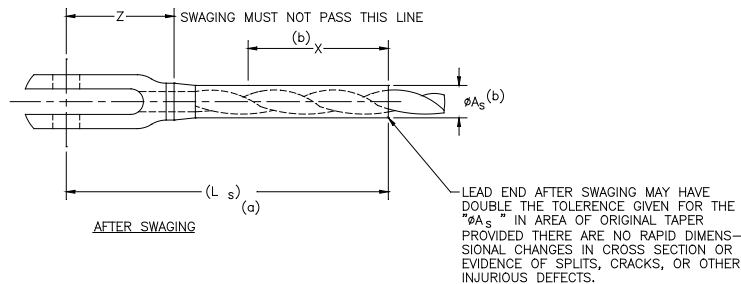
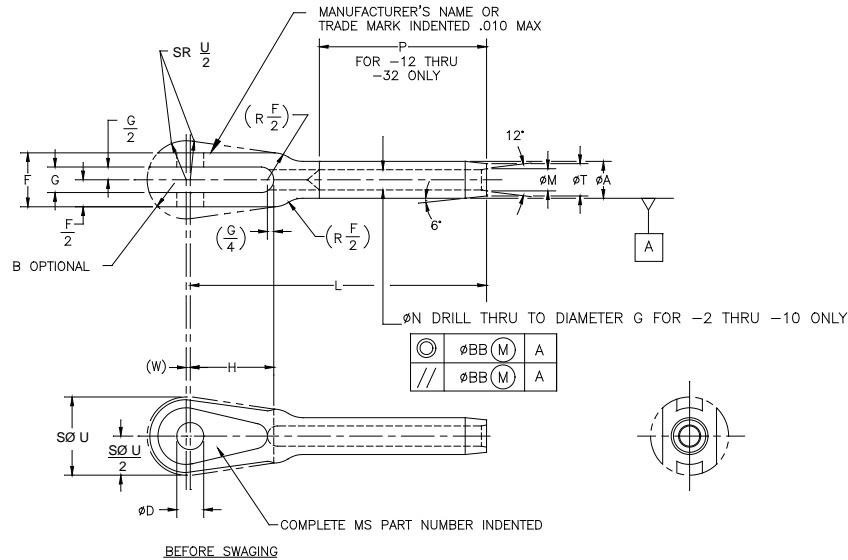

NOTES:

- (a) Reference dimensions are for design purposes only and are not an inspection requirement.
- (b) Swaged terminals shall conform to 'ØAs' for length X.
- (c) G dimension should be inspected below cross-hole.
- (d) The U dimension compliance will be determined prior to final material removed for slotting (G dimension).

FIGURE 1. Terminal, wire rope, swaging, fork end.

TABLE I. Dash numbers and dimensions.

Dash number	Wire rope diameter		Minimum breaking strength lb $\frac{1}{2}$	$\varnothing A$	$\varnothing A_s$		B radius	$\varnothing D$		F +0.010 -0.005
	Nominal	Minimum								
-2	1/16	0.062	480	0.160		0.138		0.130		0.218
-3	3/32	0.093	920	0.218		0.190		0.150	0.190	0.254
-4	1/8	0.125	2,000	0.250		0.219	+0.000 -0.005	0.220		0.383
-5	5/32	0.156	2,800	0.297		0.250		0.240	0.250	0.406
-6	3/16	0.187	4,200	0.359		0.313		0.310	0.313	0.543
-7	7/32	0.218	5,600	0.427		0.375	+0.000	0.370		0.625
-8	1/4	0.250	7,000	0.494		0.438	-0.007	0.390	0.375	0.688
-9	9/32	0.281	8,000	0.563	+0.000	0.500		0.420		0.719
-10	5/16	0.312	9,800	0.635	-0.005	0.563	+0.000	0.460	0.438	0.765
-12	3/8	0.375	14,400	0.703		0.625	-0.008	0.497	0.500	0.830
-14	7/16	0.437	17,600	0.781		0.688			0.562	
-16	1/2	0.500	22,800	0.844		0.750	+0.000	0.620	0.625	1.035
-18	9/16	0.562	28,500	0.984		0.875	-0.009	0.744	0.750	1.241
-20	5/8	0.625	35,000	1.109		1.000	+0.000 -0.010	0.810	0.875	1.351
-24	3/4	0.750	49,600	1.359		1.250		0.870		1.451
-28	7/8	0.875	66,500	1.593	+0.000	1.437	+0.000 -0.012	0.993	1.000	1.656
-32	1	1.000	85,400	1.812	-0.010	1.625		1.117	1.125	1.864

$\frac{1}{2}$ To achieve the minimum breaking strength, for the terminal test only, a galvanized carbon steel wire rope shall be used.

TABLE I. Dash numbers and dimensions - Continued.

Dash number	G		H	L +0.020 -0.000
-2	0.093		0.500	1.572
-3	0.108		0.670	1.945
-4	0.195		0.735	2.352
-5	0.202		0.800	2.655
-6	0.260		0.880	3.071
-7	0.296		0.970	3.440
-8	0.313		1.070	3.806
-9	0.327		1.170	4.120
-10	0.348		1.268	4.438
-12		0.380	1.525	5.333
-14			1.776	6.102
-16	0.473		1.903	6.938
-18	0.567		2.375	7.750
-20	0.663		2.770	8.673
-24	0.663		2.791	9.740
-28	0.756		3.170	10.802
-32	0.851		3.562	12.312

TABLE I. Dash numbers and dimensions - Continued.

Dash number	Ls reference	ØM		ØN		P		ØT		
-2	1.75	0.090	+0.010 -0.000	0.078	+0.005 -0.000			0.138	+0.000 -0.005	
-3	2.06	0.119		0.109				0.190		
-4	2.61	0.154		0.141				0.219		
-5	3.00	0.188		0.172				0.250		
-6	3.24	0.223		0.203				0.313		
-7	3.74	0.257		0.234				0.375		+0.000
-8	4.10	0.291		0.265				0.438		-0.007
-9	4.48	0.326		0.297				0.500		
-10	4.86	0.360		0.328				0.563		+0.000
-12	5.74	0.430		0.404				+0.008		3.511
-14	6.57	0.514	0.468	-0.000	4.011	0.688				
-16	7.50	0.584	+0.012 -0.000	0.531	+0.009	4.698	-0.000	0.750	+0.000	
-18	8.34	0.653		0.594	-0.000	5.011		0.875	-0.009	
-20	9.36	0.722		0.656	+0.010	5.511	+0.062 -0.000	1.000	+0.000	
-24	10.31	0.860		0.781	-0.000	6.511		1.250	-0.010	
-28	11.56	1.013	+0.015 -0.000	0.921	+0.012	7.166		1.437	+0.000	
-32	13.22	1.151		1.046	-0.010	8.229		1.625	-0.012	

TABLE I. Dash numbers and dimensions - Continued.

Dash number	SØ U +0.025 -0.010	W reference	X		Z	ØBB (FIM)	
			Minimum	Minimum	Minimum		
-2	0.344	0.031	0.70	0.60	0.016		
-3	0.438		0.80	0.75			
-4	0.547		1.05	0.91			
-5	0.688		1.29	0.96			
-6	0.781		1.31	1.13			
-7	0.906	0.047	1.55	1.25			
-8	0.969		1.70	1.36			
-9	1.156		1.89	1.43			
-10	1.265	0.063	2.06	1.50	0.020		
-12	1.500		3.12	1.89			
-14	1.750		3.57	2.16			
-16	1.875		4.31	2.31			
-18	2.340		4.51	2.81			
-20	2.730		5.04	3.23			
-24	2.750	0.093	5.80	3.30	0.030		
-28	3.125		6.31	3.70			
-32	3.510		7.26	4.15			0.040

REQUIREMENTS:

1. Material: Material shall be in accordance with MIL-DTL-781
2. Finish: Finish shall be in accordance with MIL-DTL-781.
3. Swage: Swage shall be in accordance with MIL-DTL-6117.
4. Tolerances: Unless otherwise specified, tolerances: decimals ± 0.010 , angles $\pm 3^\circ$.

NOTES:

(This section contains information of a general or explanatory nature that may be helpful, but is not mandatory.)

1. The part or identifying number (PIN) to be used for terminals acquired to this specification is created as shown below.

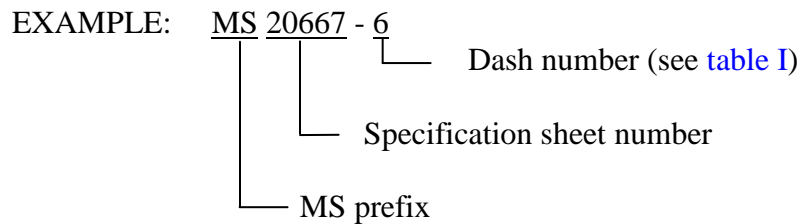

2. Dimensions are in inches.
3. Interpret drawing in accordance with ASME Y14.5M.
4. Remove burrs and sharp edges. (See MIL-DTL-781.)
5. Interchangeability relationship: MS20667 and AN667 parts identified by the same dash number are universally, functionally, and dimensionally interchangeable.
6. In the event of a conflict between the test of this document and the references cited herein, the text of this document takes precedence.
7. Unless otherwise specified, issues of referenced documents are those in effect at the time of solicitation.
8. MS20667 supersedes AN667.
9. Corrosion resistant steel parts can be universally substituted for carbon and alloy steel parts in accordance with [table II](#). Carbon and alloy steel parts are inactive for new design and cannot be substituted for corrosion resistant steel parts.

TABLE II. Substitution table.

MS PART NUMBERS	
Corrosion resistant steel	Carbon steel, cadmium plated
MS20667-2	MS20667F2
MS20667-3	MS20667F3
MS20667-4	MS20667F4
MS20667-5	MS20667F5
MS20667-6	MS20667F6
MS20667-7	MS20667F7
MS20667-8	MS20667F8
MS20667-9	MS20667F9
MS20667-10	MS20667F10
MS20667-12	MS20667F12
MS20667-14	MS20667F14
MS20667-16	MS20667F16
MS20667-18	MS20667F18
MS20667-20	MS20667F20
MS20667-24	MS20667F24
MS20667-28	MS20667F28
MS20667-32	MS20667F32

CHANGES FROM PREVIOUS ISSUE: The margins of this specification are marked with vertical lines to indicate where changes from the previous issue were made. This was done as a convenience only and the Government assumes no liability whatsoever for any inaccuracies in these notations. Bidders and contractors are cautioned to evaluate the requirements of this document based on the entire content irrespective of the marginal notations and relationship to the last previous issue.

Custodians:
 Army - CR4
 Navy - AS
 Air Force - 99

Preparing Activity:
 DLA - GS5

(Project 1640-2011-008)

Review Activities:
 Army - MD
 Air Force - 71

NOTE: The activities listed above were interested in this document as of the date of this document. Since organizations and responsibilities can change, you should verify the currency of the information above using the ASSIST database at <https://assist.daps.dla.mil/>.